

EZL-200L User's Manual

Version 1.4



SollaE Systems



To all residents of the European Union

Important environmental information about this product

This symbol on this unit or the package indicates that disposal of this unit after its lifecycle could harm the environment. Do not dispose of the unit as unsorted municipal waste; it should be brought to a specialized company for recycling. It is your responsibility to return this unit to your local recycling service. Respect your local environmental regulation. If in doubt, contact your local waste disposal authorities.

- Table of Contents -

1. OVERVIEW	- 5 -
1.1. OVERVIEW	- 5 -
1.2. COMPONENTS.....	- 6 -
1.3. SPECIFICATIONS	- 6 -
1.4. INTERFACE	- 7 -
1.4.1. Power	- 7 -
1.4.2. Dsub Connector	- 7 -
1.4.3. LEDs.....	- 8 -
1.4.4. Ethernet Interface.....	- 9 -
2. INSTALLATION AND TEST RUN	- 10 -
2.1. INSTALLATION METHOD.....	- 10 -
2.1.1. Checking the Communication Environment.....	- 10 -
2.1.2. Connecting to the Network.....	- 10 -
2.1.3. Configuring the Environmental Variables	- 11 -
2.2. TEST RUN.....	- 11 -
2.2.1. Changing PC IP Address.....	- 11 -
2.2.2. Installation EZL-200L.....	- 11 -
2.2.3. Configuring EZL-200L.....	- 11 -
2.2.4. Connecting to the PC Serial Port.....	- 12 -
2.2.5. Communication Test	- 12 -
3. CONFIGURING IP ADDRESS AND ENVIRONMENTAL VARIABLES	- 13 -
3.1. IP ADDRESS AND ENVIRONMENTAL VARIABLES	- 13 -
3.2. CONFIGURATION BY EZCONFIG	- 17 -
3.2.1. ezConfig Menu	- 17 -
3.2.2. Example configuration of ezConfig (LOCAL).....	- 19 -
3.2.3. Example configuration of ezConfig (REMOTE).....	- 21 -
3.3. AT COMMAND.....	- 22 -
3.4. SETTING IP ADDRESS-RELATED ITEMS BY DHCP	- 22 -
3.5. SETTING IP ADDRESS-RELATED ITEMS BY PPPoE	- 22 -
4. OPERATION MODE	- 23 -
4.1. OPERATION MODE OVERVIEW	- 23 -
4.1.1. Overview	- 23 -
4.2. HOW TO INITIATE EACH OPERATION MODE.....	- 23 -

4.2.1.	<i>How to Initiate Normal Mode</i>	- 23 -
4.2.2.	<i>How to Initiate ISP Mode</i>	- 23 -
4.2.3.	<i>Comparison of Operation Modes</i>	- 23 -
4.3.	NORMAL COMMUNICATION MODE.....	- 23 -
4.4.	ISP MODE.....	- 24 -
5.	NORMAL COMMUNICATION MODE	- 26 -
5.1.	T2S(TCP TO SERIAL)	- 26 -
5.2.	ATC (AT COMMAND).....	- 28 -
5.3.	COD (CONNECT ON DEMAND).....	- 30 -
5.4.	U2S.....	- 32 -
6.	ATC MODE	- 34 -
6.1.	OVERVIEW	- 34 -
6.1.1.	<i>AT command format</i>	- 34 -
6.2.	BASIC AT COMMAND SET (EXAMPLE: ATA, ATD ETC.)	- 34 -
6.3.	EXTENDED AT COMMANDS (EXAMPLE: AT+PLIP ETC.)	- 35 -
6.4.	ONLINE STATE AND ONLINE COMMAND STATE	- 35 -
6.4.1.	<i>Changing Online State to Online Command State</i>	- 35 -
6.4.2.	<i>Changing Online Command State to Online State</i>	- 36 -
6.5.	EXAMPLE OF CONFIGURATION WITH AT COMMAND.....	- 36 -
6.6.	EXAMPLE OF TCP CONNECTION	- 36 -
6.6.1.	<i>Example of Active Connection</i>	- 36 -
6.6.2.	<i>Example of passive Connection</i>	- 37 -
6.7.	EXAMPLE OF TCP DISCONNECTION	- 37 -
6.7.1.	<i>Example of active disconnection</i>	- 37 -
6.7.2.	<i>Example of passive disconnection</i>	- 37 -
7.	TECHNICAL SUPPORT, WARRANTY, AND NOTES ON OPERATION.....	- 38 -
7.1.	TECHNICAL SUPPORT	- 38 -
7.2.	WARRANTY	- 38 -
7.2.1.	<i>Refund</i>	- 38 -
7.2.2.	<i>Free Repair Services</i>	- 38 -
7.2.3.	<i>Charged Repair Services</i>	- 38 -
7.2.4.	<i>Notes on Operation</i>	- 38 -
8.	REVISION HISTORY	- 40 -

1. Overview

1.1. Overview

Along with the development of the Internet, the demand for data communication functions has increased recently. Data communication over the Internet requires using TCP/IP, the Internet communication protocol. That is to say, in order to connect a system to the Internet, TCP/IP protocol must be implemented. It is possible to implement TCP/IP by directly implementing the protocol, porting public TCP/IP, or using Operating System (OS). However, all these methods impose burdens on the developer in time, cost, and technology.

ezTCP series, a Serial ↔ TCP/IP protocol converter product group of Sollae Systems, enables you to use TCP/IP communication (the Internet communication) function simply by “connecting the cable to a serial port”. ezTCP sends data from the serial port to the Internet network after TCP/IP processing, and vice versa.

EZL-200L in ezTCP product group is a product that provides TCP/IP communication through Ethernet. In other words, like other ezTCP products, EZL-200L sends data from the serial port to the LAN after TCP/IP processing and vice versa.

It provides DHCP and PPPoE functions as well as TCP/UDP/IP, so that it can be applied to the cable network and the xDSL network.

EZL-200L is low-cost TCP/IP solution that is integrated highly and optimally in a small hardware.

1.2. Components

- EZL-200L Body
- 5V Power Adaptor (Option)
- RS232C cable for PC connection (Option)
- Cross-over Ethernet cable (Option)

1.3. Specifications

Power	Input Voltage	5V ($\pm 10\%$)
	Current	78mA typical
Dimension	136mm x 83mm x 29mm	
Weight	About 140g	
Interface	Serial	9pin Dsub male
	Network	10- Base T
Serial Port	RS232 (1200bps ~ 115200bps)	
Network	10Base-T	
Protocols	TCP, UDP, IP, ICMP, ARP, DHCP, PPPoE	
Communication Mode	T2S	TCP Server Mode
	COD	TCP Client Mode
	ATC	TCP Server/Client Mode (AT command emulation)
	U2S	UDP
Utilities	ezConfig	Configuration utility via LAN
	ezterm	Socket test utility
	hotflash	Firmware download utility via TFTP

☞ You can download free utilities and firmware from <http://www.eztcp.com>.

1.4. Interface

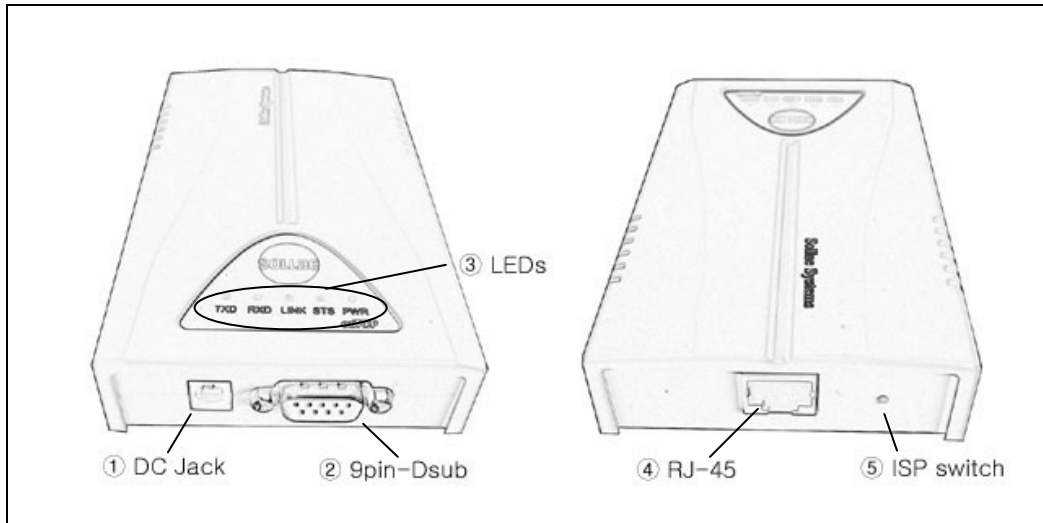

1.4.1. Power

DC 5V is used for EZL-200L and the specification is below:

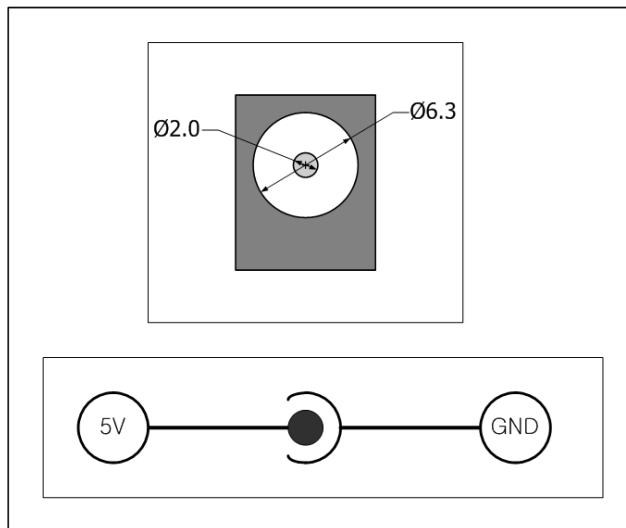

1.4.2. Dsub Connector

The connector of serial port is 9 pin Dsub male. The specification is below:

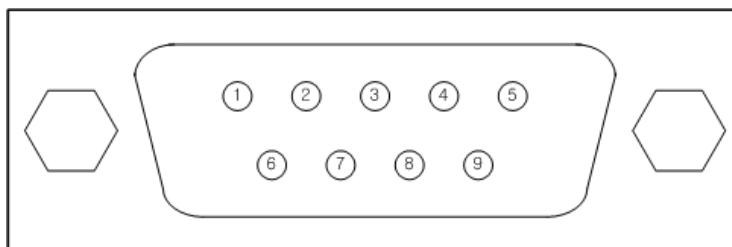

● RS-232

#	name	description	level	Dir.	Etc.
1	-	-	-	-	-
2	RXD	Receive Data	RS232	Input	Mandatory
3	TXD	Transmit Data	RS232	Output	Mandatory
4	DTR	Data Terminal Ready	-	-	DTR/DSR loopback jumper
5	GND	Ground	Ground	-	Mandatory
6	DSR	Data Set Ready	-	-	DTR/DSR loopback jumper
7	RTS	Request To Send	RS232	Output	Optional
8	CTS	Clear To Send	RS232	Input	Optional
9	-	-	-	-	-

Pin 4 and pin 6 will be loop-backed when JP2 is on. JP2 is inside of EZL-200L.

1.4.3. LEDs

EZL-200L has 5 LEDs.

Each LED functions as follows:

Name	Meaning	Color	LED Status	Description
PWR	Power	Red	ON	Power is supplied
STS	Status	Yellow	Blinking for a second	IP is allocated but TCP connection is not established
			Blinking 4 times/sec	IP is not allocated
			ON	TCP connection is established
			Rapidly Blinking	ISP Mode
LINK	LAN Link	Green	ON	Connected to ethernet
RXD	LAN Rx	Yellow	Blinking	There are data on the LAN

TXD	LAN Tx	Green	Blinking	Packets are being transmitted to Ethernet
-----	--------	-------	----------	--

1.4.4. Ethernet Interface

The interface of EZL-200L is 10Base-T. 1:1 cable should be used for connection with a HUB and cross-over cable should be used for connection with PC directly without any HUB.

Each piece of Ethernet equipment has unique hardware addresses, and EZL-200L also has factory-set hardware address (which is called MAC address).

2. Installation and Test Run

2.1. Installation Method

You can install EZL-200L in the following steps:

Title	Item	Sub-item	Description
1. Checking the communication environment	Check items	IP address environment	3.1.
		Serial port settings	3.1.
		Application program to be used	4.
2. Connecting to the network	Check method	Check if LINK LED is ON.	1.4.4.
3. Configuring the environmental variables	Configuration method	Set by ezConfig, a utility program for configuration through the network.	3.2.
		Set by AT commands in ATC mode	6.
	Configuration items	IP address related items	3.1.
		Serial port related items	3.1.
		Communication mode (Decided depending on application program)	4.
4. Application to the field			

2.1.1. Checking the Communication Environment

Before installing EZL-200L, check the network environment where EZL-200L is to be installed, including the followings matters:

- IP address environment (local IP, subnet mask, gateway, etc.)
- Serial port items of the equipment to which EZL-200L is going to be connected (baud rate, data bit, parity, stop bit)
- Application program protocol to be used (TCP/UDP, server/client, SSL, etc.)
- For application program protocol to be used, see “5. Normal Communication Mode”.

2.1.2. Connecting to the Network

Connect power to EZL-200L, and connect EZL-200L directly to the Ethernet port of the

PC where test is to be performed with a cross-over Ethernet cable.

2.1.3. Configuring the Environmental Variables

When network connection is completed, configure the environmental variables such as IP address related items, serial port related items, and communication mode related items through the LAN using “ezConfig,” the environmental variable configuration program.

☞ *For environmental variable configuration, see “3. Setting IP Address and Environmental Variables.”*

2.2. Test Run

You can perform test run according to the following orders. The test run described here is based on the assumption that the IP address of the PC is set to 10.1.0.2.

2.2.1. Changing PC IP Address

You can change the IP address of your PC as follows:

IP Address	10.1.0.2
Subnet Mask	255.0.0.0
Gateway IP Address	0.0.0.0

2.2.2. Installation EZL-200L

Connect the supplied RS232 cable between your PC and EZL-200L, the LAN cable to the hub to which the PC is connected or directly to the PC with a cross-over cable, and the supplied EZL-200L power adapter to EZL-200L for power supply. If the LAN cable has been correctly connected when power is supplied, LINK LED turns on.

2.2.3. Configuring EZL-200L

Configure EZL-200L setting using ezConfig, the ezTCP configuration program, as follows.

Run ezConfig, and click [Search ezTCP] button in the ezConfig window. And, ezConfig program will search all ezTCPs on the local network.

When ezTCP is searched, MAC address of the ezTCP is displayed on the [Search List] window (The MAC address is indicated at the bottom of the product case).

Select the corresponding MAC address, and set the same as shown in the following figure and click [Write] button to save the settings.

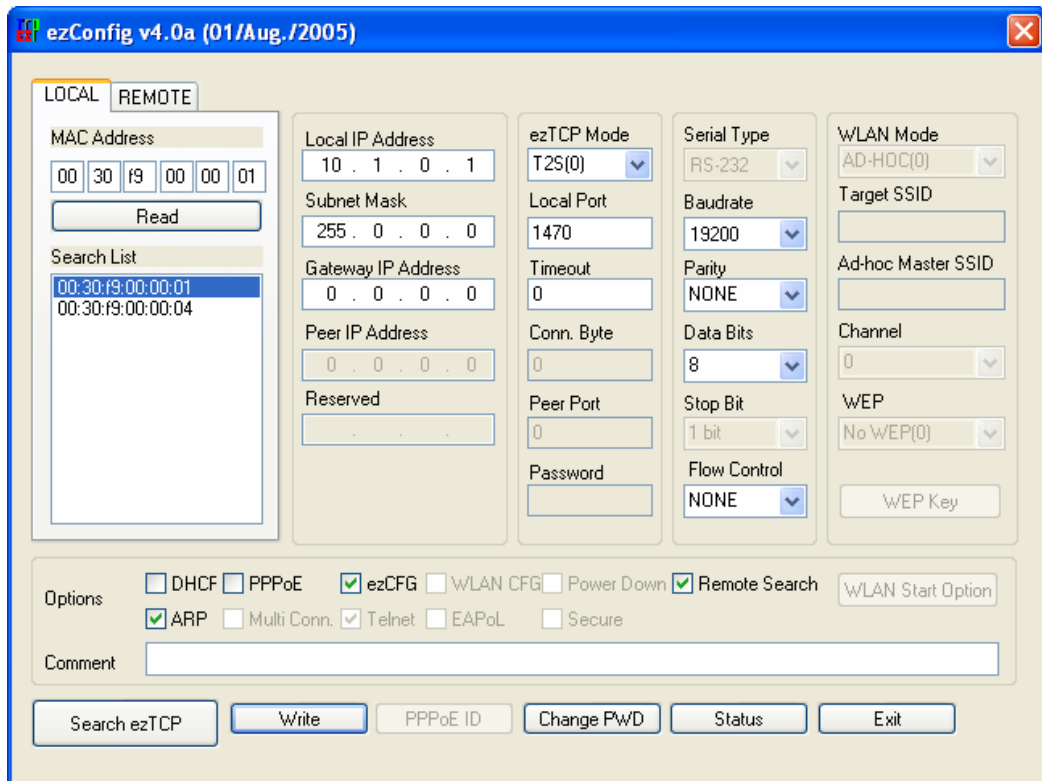

2.2.4. Connecting to the PC Serial Port

Connect the serial port of your PC and that of EZL-200L, using the supplied serial communication cable. Then, run serial communication program such as Hyper Terminal and Teraterm. When the program is run, select the same serial port values as those set to EZL-200L [19200bps, data bit: 8 bits, stop bit: 1 bit, no parity], which will finish the preparation for serial communication.

2.2.5. Communication Test

When the preparation for serial communication is finished, enter the following in the DOS window on your PC, to connect to TCP through Telnet program.

"Telnet 10.1.0.1 1470"

When TCP connection succeeds, STS LED of EZL-200L turns ON.

When the STS LED turns ON, enter "123" on the Telnet window, and "123" will appear on the hyper terminal. Enter "ABC" on the hyper terminal, and "ABC" will appear on the Telnet window. Otherwise, communication test fails.

3. Configuring IP Address and Environmental Variables

3.1. IP Address and Environmental Variables

For TCP/IP communication, you must set IP address related items. In addition, you have to set serial port related items (baud-rate, data bit length, parity bit, flow control, etc) to EZL-200L.

You can set the IP address and the serial port related items by using ezConfig, the supplied configuration utility which allows you to configure your EZL-200L over the network, or by using AT commands in ATC mode.

	Item	Description
IP Address-related Items	Local IP Address	IP address of EZL-200L
	Subnet Mask	Subnet mask
	Gateway IP Address	IP address of gateway
	Local Port	Port number for waiting to be connected in Server mode Port number for waiting UDP data
	Peer IP Address	IP address to connect in Client mode IP address to send data in UDP mode
	Peer Port	Port number to connect in Client mode Port number to send data in UDP mode
	Permitted IP Address	Permitted IP address in server mode.
Serial Port	Baudrate	Serial Port Speed(bps)
	Data bits	Data bit length
	Parity	Parity
	Stop bit	Stop bit
	Flow Control	Flow control
Communication Mode	ezTCP Mode	Communication Mode

Connect/Disconnect Event	Conn. Byte	Minimum number of bytes attempting to connect/transmit
	Timeout	Limit time to keep connection
Configuration Method Used	ezConfig	Enable ezConfig function.
	Remote Search	Remote configuration function with UDP unicast
	Password	Select between Telnet password and ezConfig password.
	ARP	Enable IP setting by ARP.
Dynamic IP Address	DHCP	Select to receive EZL-200L IP address as DHCP.
	PPPoE	Select to receive EZL-200L IP address as PPPoE.
	PPPoE ID & Password	ID and password to be used for PPPoE

- Local IP Address

IP address of EZL-200L. If you set DHCP or PPPoE is set, an IP address is automatically allocated. So, you cannot set the local IP address.

- Subnet Mask

Sets subnet mask of the network where EZL-200L is installed

- Gateway IP Address

Sets the gateway IP address of the network where EZL-200L is installed.

- Permitted IP Address

It is a permitted IP address of foreign host when EZL-200L operates as a server. The only host that is written in this item can connect to EZL-200L. If Permitted IP Address is 0.0.0.0, all hosts can connect to the EZL-200L.

- Local Port

Port number, which is used as TCP port number waiting to be connected when EZL-200L operates as TCP server or as the port number waiting for UDP data when it operates in U2S communication mode.

- Peer Port

Local port number of the server to connect when EZL-200L operates as TCP client or to transmit UDP data when it operates as U2S

- Baudrate

Selects a serial port speed (1200 bps ~ 115200bps).

- Data bits

Selects a data bit length of the serial port (7 bits or 8 bits)

- Parity

Select a parity bit of the serial port (None, Even, Odd).

- Stop bit

Selects a stop bit length of the serial port (1 bit, 2 bits).

- Flow Control

Selects flow control for the serial port (None, RTS/CTS, Xon/Xoff).

- ezTCP Mode

Selects the communication mode of EZL-200L (T2S, ATC, COD, U2S).

- Conn. Byte

Decides a point of time to start connection when EZL-200L operates as COD. EZL-200L starts to connect to the host (Peer IP Address and Peer Port) of the designated host upon receiving as many data as specified by [Conn. Byte] from the serial port.

- Block(Byte)

Decides the size of UDP packet to be sent at a time when EZL-200L operates as U2S.

- Timeout

When EZL-200L operates as TCP such as T2S, COD and ATC, connection is closed if data communication is not continued as long as the time set to this item unless this item is set to 0 (unit: second)

- Interval

When EZL-200L operates as UDP like U2S, it transmits data in blocks by gathering data for the time set to this item (unit: 10ms)

- ezConfig

You can use ezConfig utility only this item is enabled.

(If this item is not enabled, you cannot set EZL-200L using ezConfig. Therefore, it is recommended to enable this all the times.)

To enable ezConfig, set this item in ISP mode.

- Remote Search

If this item is set, EZL-200L in other network can be configured by ezConfig. Remote Search function is performed in the [REMOTE] tab.

- Password

Sets a password for configuring with ezConfig. If user forgot the password, the user can delete the password in ISP mode.

- ARP

When this item is selected, EZL-200L uses the destination IP address of the first packet coming to its MAC address as its own IP address temporarily. This item should be set in DHCP environment if required.

- DHCP

Set to receive an IP address as DHCP.

- PPPoE

Set to receive an IP address as PPPoE.

- PPPoE ID & Password

Sets ID and password used for PPPoE.

EZL-200L uses maximum 32 byte for saving an ID and 8 bytes for a password.

- Comment

Stores maximum 32 byte user comment on the product. This item helps the user distinguish each EZL-200L more easily.

3.2. Configuration by ezConfig

3.2.1. ezConfig Menu

The basic environmental variables (IP address related items, serial port items, and etc.) can be set by ezConfig which is an integrated management tool for Windows.

ezConfig is operated in Microsoft Windows(Windows 98, 98 SE, 2000 Pro, ME, XP Pro/Home). Following is the screen shot of ezConfig which is just launched.

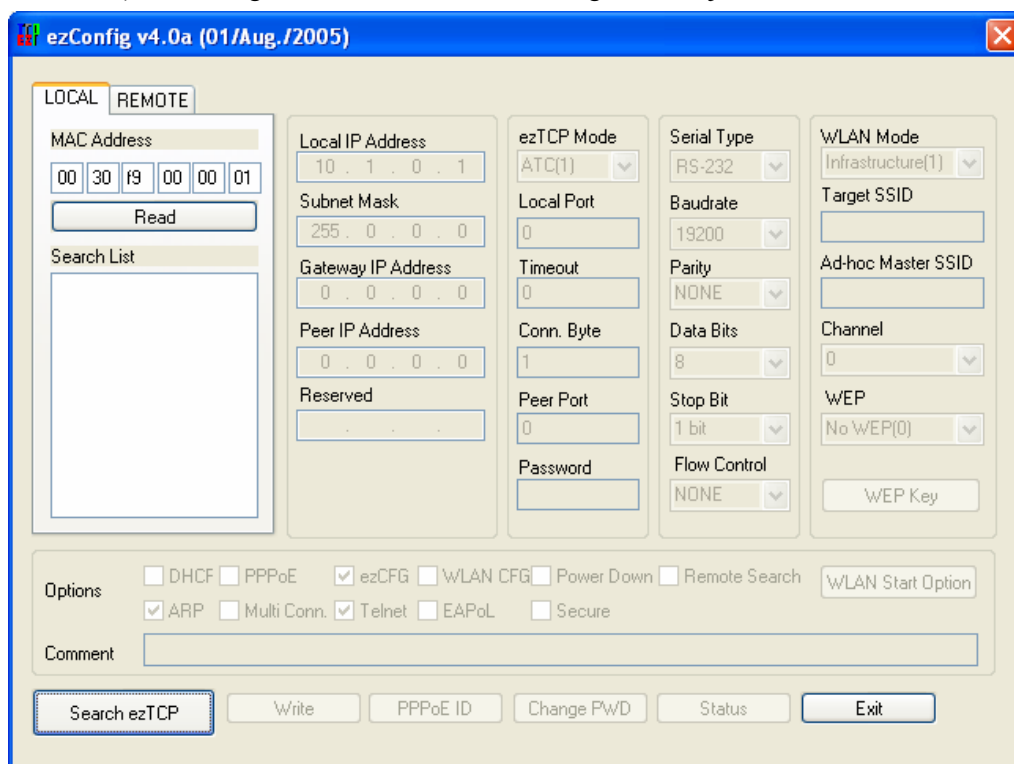

√ ezConfig can set not only EZL-200L's environmental variables but also other ezTCP series.

ezConfig configures ezTCP by Ethernet, there are two way to configure.

The first way is UDP broadcast. When using UDP broadcast, user can search all ezTCPs in the same network without knowledge of IP address. But beware that it can be used in the 'same network'. This method performed in the [LOCAL] tab of ezconfig version above 4.0.

The second way is UDP unicast that communicates by IP address. As it configured with IP address, EZL-200L is configured any place if they are connected with network. This method performed in the [REMOET] tab of ezconfig version above 4.0.

(ezConfig below version 4.0 supports only UDP broadcast)

	LOCAL	REMOTE
communication	UDP broadcast	UDP unicast (port: 50005)
search	With MAC address	with IP address
location	In the same network with EZL-200L	Can be used in a different network

The functions of ezConfig's buttons are followed:

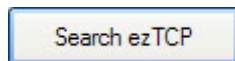

This button is used to search for all of the network-attached ezTCPs.

The search results will be displayed on the [Search List] box and you can select an item using a mouse or cursor as required. The value displayed on the box indicates the MAC ADDRESS of each ezTCP. The selected setup value of ezTCP will be displayed on the right side.

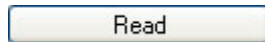

[LOCAL]tab:

You can see only the ezTCP configuration values if you press this button after entering the 6-digit hexadecimal number printed on the ezTCP main body in the MAC ADDRESS box. It is useful when there are too many ezTCPs attached to the network to search for one from the LIST box.

[REMOTE] tab:

Reading environmental variables with the IP address.

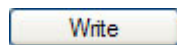

This button is used to save the changed value in ezTCP after modifying the configuration. Make sure not to press this button during operating ezTCP since ezTCP will automatically be reset right after its environment setup value is saved. Otherwise, it may cause malfunction.

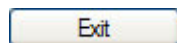

Terminating ezConfig.

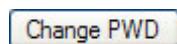

ezTCP provides User Authentication function to prevent an unwanted person from modifying the configuration. The authentication process is performed through the password string verification. When entering or changing the password strings, you can use this button. Changing the ezTCP configuration details if a password

has been entered requires the proper password to be entered in the PASSWORD field.

√ *If you forget the password, erase or reenter in ISP Mode.*

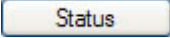
 This button is used to read a dynamic status during operating ezTCP. Pressing this button will display a new window, where the time-elapsed after the power is on, the current IP address, and the data throughput of the serial port are indicated. Double-clicking each item on the [Search List] will carry out the same function.

3.2.2. Example configuration of ezConfig (LOCAL)

ezConfig can be used to change the IP address related items, the serial port setup value, the serial port operation mode. This section describes these functions briefly. For more information, see the following sections.

The following example shows how to read and change ezTCP's basic functions. Try changing ezTCP setup value according to the following sequence

- When the ezTCP power is turned on and the LAN cable is connected correctly, pressing [Search] or [Read] button will display the following window:

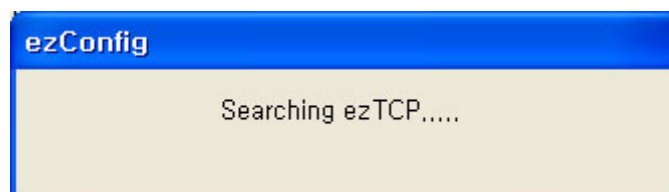

- If a network-attached ezTCP is detected, the following message will be displayed. If a message pops up indicating that there is no response from ezTCP, check that the power is turned on and the cable is connected correctly, then try pressing [Search] or [Read] button.

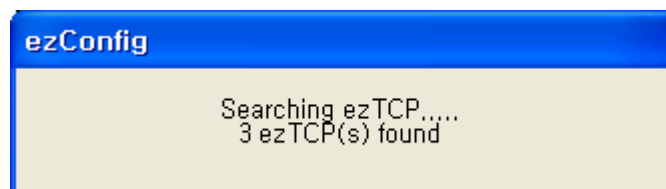

√ *It is impossible to use ezConfig, if EZCFG check box is disabled. This function can be*

re-enabled in ISP mode.

- If more than one ezTCP are detected, ezTCP's MAC ADDRESS will be displayed in the [Search List] box on ezConfig. Check if the MAC ADDRESS displayed in the [Search List] window corresponds to that printed on ezTCP main body. The following screen shows this process:

Following is the screenshot when ezTCPs were found.

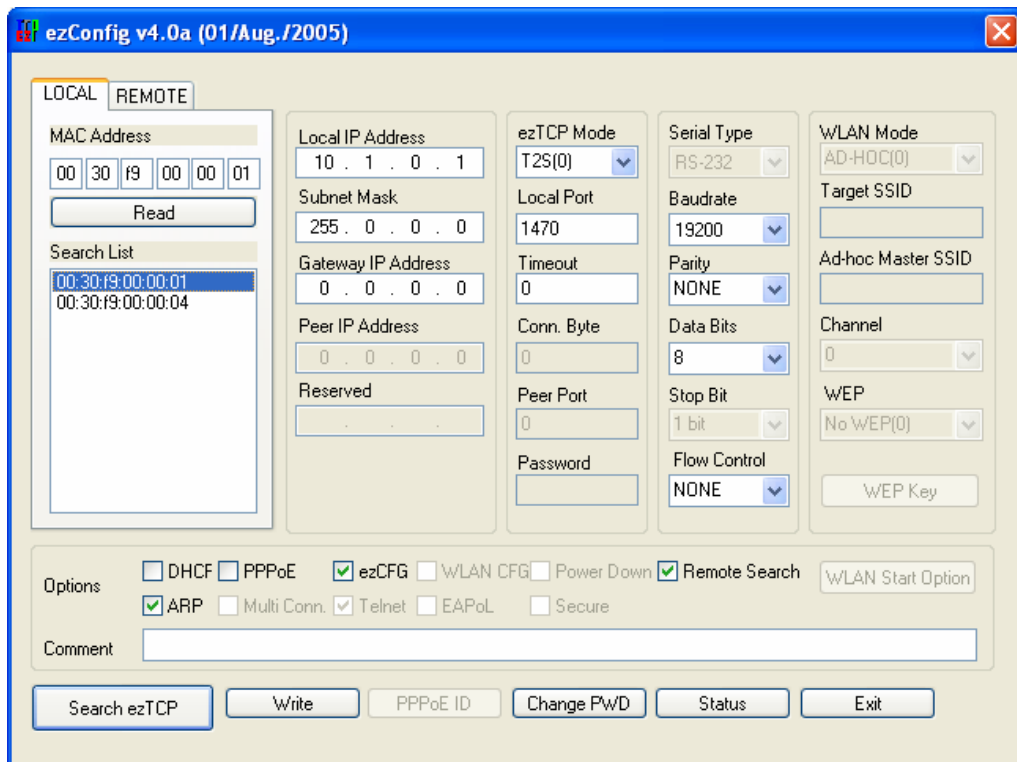

- Set [ezTCP Mode], [Local IP Address], [Local Port], and serial port related items. After setting press [Write] button. If there is any error during writing process, check the LAN between PC and EZL-200L.
- Check if the set IP address is correct with ping command in DOS prompt. Following is the message if the IP address is OK. If "Request timed out" message is shown, check IP address.

```

C:W>ping a.b.c.d
Pinging a.b.c.d with 32 bytes of data:
Reply from a.b.c.d: bytes=32 time=1ms TTL=64
Reply from a.b.c.d: bytes=32 time=1ms TTL=64
Reply from a.b.c.d: bytes=32 time=1ms TTL=64
Reply from a.b.c.d: bytes=32 time=1ms TTL=64

```

<When IP address is a.b.c.d.>

√ *IP address, subnet mask, and gateway IP address of both PC and EZL-200L should be correct to succeed in ping test.*

3.2.3. Example configuration of ezConfig (REMOTE)

- Input the IP address of EZL-200L in IP address field in the [REMOTE] tab, and press [Read] button. Then following window will be appeared.

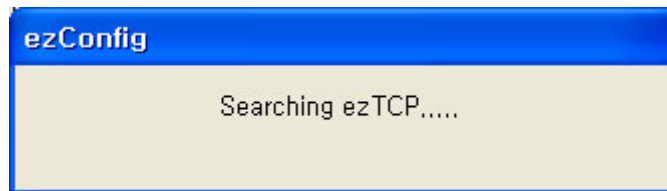

- If the EZL-200L is found, the following will be shown.

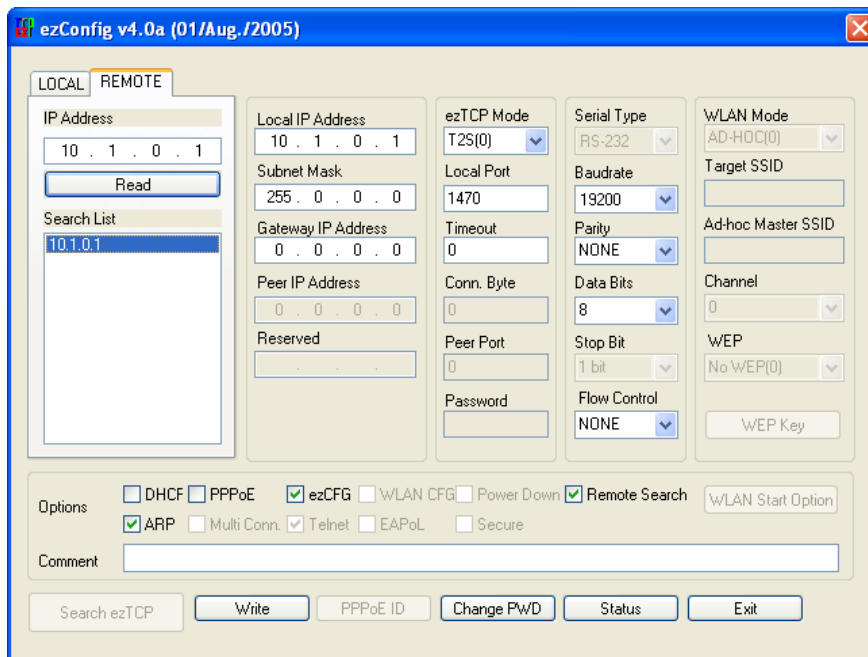

- Configure variables and press [Write] button.

3.3. AT command

In ATC mode, the user can set environment variables through the serial port using AT command.

☞ *For more information, See “6. ATC Mode”.*

3.4. Setting IP Address-related Items by DHCP

Under environment with a network operating a DHCP server, DHCP protocol allows the user to automatically set the IP address, subnet mask, gateway, and name server of ezTCP. Using DHCP automatic setup function requires the user to check [DHCP] item on ezConfig. Note that the user may have to check [ARP] item according to the type of DHCP servers.

3.5. Setting IP Address-related Items by PPPoE

PPPoE is used in most ADSL and VDSL. To use PPPoE function, PPPoE function should be enabled and PPPoE ID and PPPoE password should be configured. The local IP address of EZL-200L is assigned automatically in PPPoE environment.

√ *Some ADSL or VDSL modem use DHCP. Please contact your ISP (Internet Service Provider).*

4. Operation Mode

4.1. Operation Mode Overview

4.1.1. Overview

EZL-200L can operate in one of two modes (normal and ISP modes). Normal mode is ordinary data communication mode; and ISP mode is used to download EZL-200L firmware through the Ethernet(TFTP).

4.2. How to Initiate Each Operation Mode

4.2.1. How to Initiate Normal Mode

Normal mode is a mode in which EZL-200L performs its original functions. If you do not make any change in the default setting, EZL-200L usually operates in normal mode.

☞ *For more information, see “5. Normal Communication Mode.”*

4.2.2. How to Initiate ISP Mode

Supply power to EZL-200L with pressing the ISP button on the back of the product, and EZL-200L operates in ISP mode. During ISP mode, the STS LED of EZL-200L will blink rapidly.

4.2.3. Comparison of Operation Modes

The following table is the comparison of the above described operation modes.

Mode	How to Initiate	Description	Serial Port
normal	-	Normal data communication mode T2S, ATC, COD, U2S	User setting
ISP	Supply power with pressing the button or press the button about 2 seconds	Download firmware through the ethernet	19200bps,N,8,1

4.3. Normal Communication Mode

Normal communication mode is suitable for the purpose of using EZL-200L.

Normal communication mode can be classified into four modes – T2S, ATC, COD, and

U2S – each of which is described in the following table.

Communication Mode	Protocol	Connection	Need for User Equipment Software Modification	Configuration of Environmental Variables through Serial Port	Topology
T2S	TCP	Passive Connection	Not needed	Impossible	1:1
ATC	TCP	Active/Passive Connection	Needed	Possible	1:1
COD	TCP	Active Connection	Not needed	Impossible	1:1
U2S	UDP	No Connection	Not needed	Impossible	N:M

TCP protocol requires connection process. The connection is always established as 1:1 connection. At this time, the host waiting for connection (passive connection) is called a server and the one attempting to connect (active connection) is called a client.

On the other hand, UDP communicates by block unit without connection process. As UDP does not require connection, numbers of hosts can communicate at the same time.

☞ *For more information on communication modes, refer to the next chapter.*

4.4. ISP Mode

In ISP mode, you can download the latest firmware (EZL-200L operation software) provided by our company.

The following section describes how to download firmware in ISP mode.

- Supply power to EZL-200L with pressing the ISP button on the back of the product. Then, the STS LED will be blink rapidly.
- Run hotflash that is supplied by us.

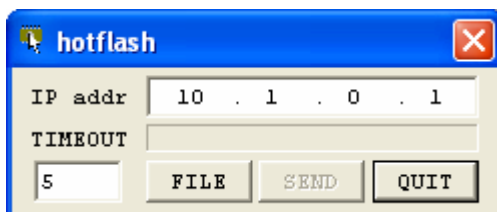

- Select a firmware in the [FILE] menu, and input the IP address of EZL-200L and press [SEND] button. Then the firmware will be transferred by Ethernet.



- After completion, a message that informs the firmware was downloaded successfully. And EZL-200L reboots automatically and run in Normal Mode. In Normal Mode, STS LED is blink every 1 second.

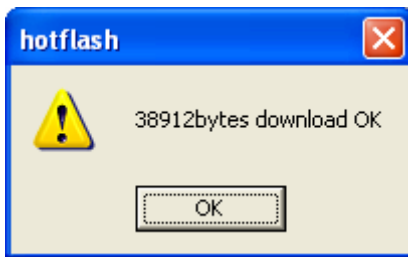

5. Normal Communication Mode

5.1. T2S(TCP To Serial)

When a host connects to predefined local port, the EZL-200L accepts a TCP connection. When the EZL-200L accepts TCP connection, then the TCP connection is established. After connection is established, TCP/IP processing is performed on the data coming to the serial port, which is then transmitted to the remote host. And the TCP/IP data coming from the remote host is TCP/IP-processed and transmitted to the serial port to establish data communication. (Data coming to the serial port before TCP connection is established will be ignored.)

To limit the peer host, user should set [Peer IP Address]. The only pre-defined host can be accessible. If [Permitted IP Address] is 0.0.0.0, any host can connect to EZL-200L.

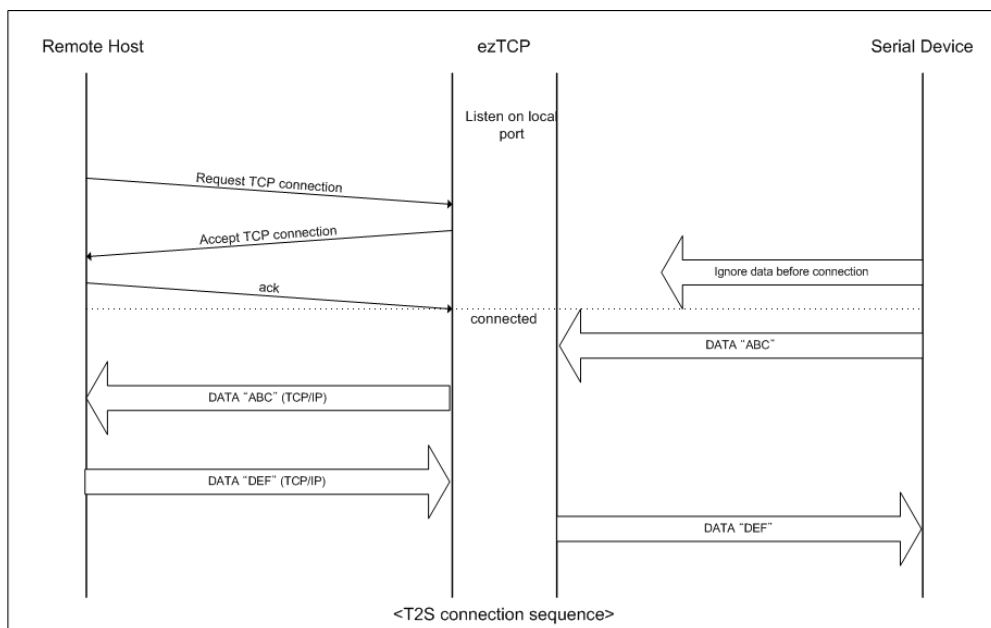

Set the following for T2S mode:

	Item	Description
IP Address Related Items	Local IP Address	IP address of EZL-200L
	Subnet Mask	Subnet mask
	Gateway IP Address	IP address of gateway
	Local Port	Port number for waiting to be connected in Server mode
	Permitted IP Address	Permitted host to connect (if set to 0.0.0.0, any host can connect)
Serial Port	Baudrate	Serial port speed (bps)
	Data bits	Data bit length
	Parity	Parity
	Stop bit	Stop bit
	Flow Control	Flow control
Communication Mode	ezTCP Mode	Communication Mode (T2S(0))
Disconnection	Timeout	Limit time to keep connection
Configuration Method	ezConfig	Enable ezConfig function.
	Password	ezConfig password.
Dynamic IP	DHCP	Select to receive EZL-200L IP address as DHCP.
	PPPoE	Select to receive EZL-200L IP address as PPPoE.

5.2. ATC (AT Command)

In ATC mode, the user can control the EZL-200L in a similar way to controlling the modem using AT command. In ATC mode, only a TCP connection is possible and both the server and the client can be configured.

In ATC mode, the AT command allows the user to set environment variables including the IP address and control TCP connection and disconnection.

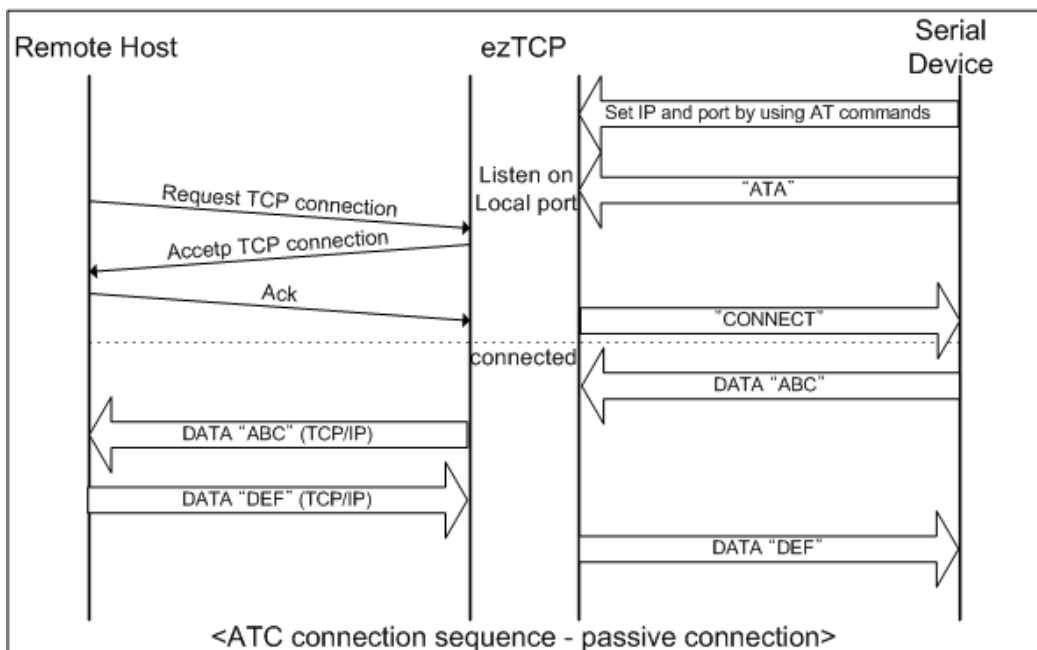
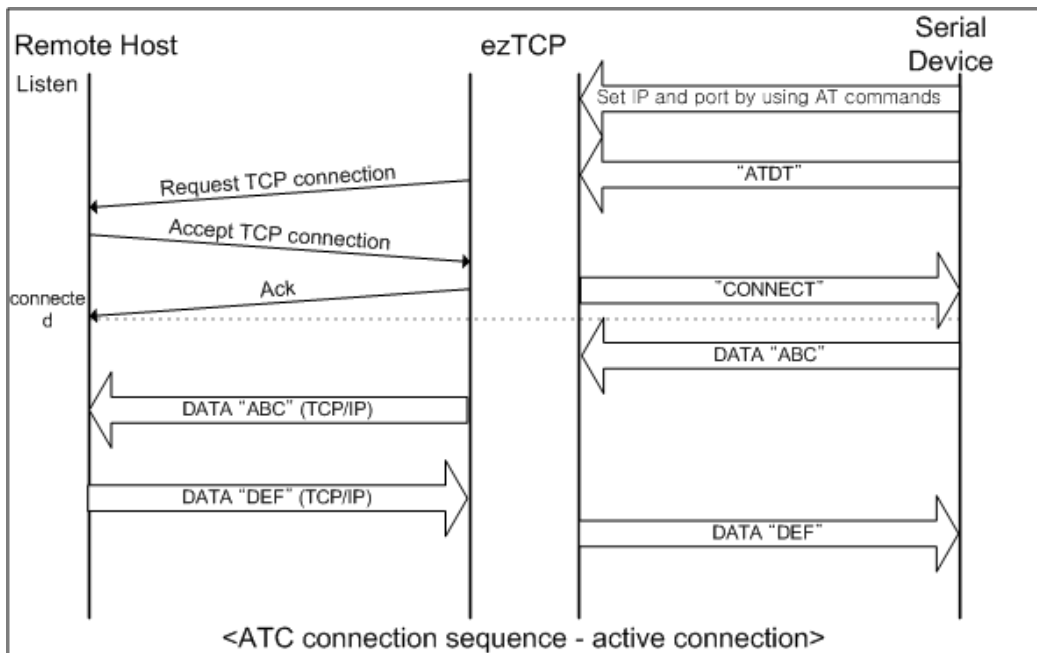

Set the following for ATC mode.

	Item	Description
IP Address Relate Items	Local IP Address	IP address of EZL-200L
	Subnet Mask	Subnet mask
	Gateway IP Address	IP address of gateway
	Local Port	Port number for waiting to be connected in Server mode
	Peer IP Address	Peer IP address to connect
	Peer Port	Peer port number to connect
Serial Port	Baudrate	Serial port speed (bps)
	Data bits	Data bit length
	Parity	Parity
	Stop bit	Stop bit
	Flow Control	Flow control
Communication Mode	ezTCP Mode	Communication mode(ATC(1))
Disconnection	Timeout	Limit time to keep connection
Configuration Method	ezConfig	Enable ezConfig function.
	Password	ezConfig password.
Dynamic IP	DHCP	Select to receive EZL-200L IP address as DHCP.
	PPPoE	Select to receive EZL-200L IP address as PPPoE.

 See "6. ATC Mode."

5.3. COD (Connect On Demand)

In COD mode, the EZL-200L functions as a client.

When data of the pre-specified size [CONN BYTE] comes to the serial port, the EZL-200L attempts a TCP connection to the TCP port [PEER PORT] of the preset host IP [PEER IP ADDRESS]. If the remote host accepts the TCP connection, TCP connection will be established. Data coming to the serial port after connection establishment is TCP/IP-processed and transmitted to the remote host. And, data coming from the remote host is TCP/IP-processed and transmitted to the serial port for data communication.

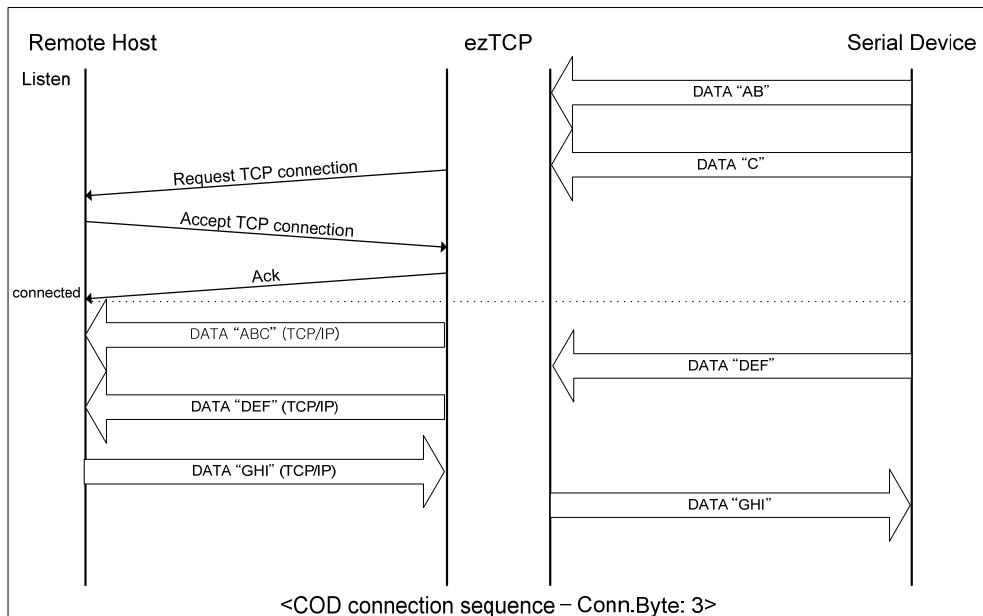

Set the following for COD mode.

	Item	Description
IP Address Related Item	Local IP Address	IP address of EZL-200L
	Subnet Mask	Subnet mask
	Gateway IP Address	IP address of gateway
	Peer IP Address	Peer IP address to connect
	Peer Port	Peer port number to connect
Serial Port	Baudrate	Serial port speed (bps)
	Data bits	Data bit length
	Parity	Parity
	Stop bit	Stop bit
	Flow Control	Flow control
Communication Mode	ezTCP Mode	Communication mode(COD(2))
Connection/ Disconnection	Conn. Byte	Bytes for starting to connect
	Timeout	Limit time to keep connection
Configuration Method	ezConfig	Enable ezConfig function.
	Password	ezConfig password
Dynamic IP Address	DHCP	Select to receive EZL-200L IP address as DHCP.
	PPPoE	Select to receive EZL-200L IP address as PPPoE.

5.4. U2S

U2S mode allows for UDP communication.

In UDP mode, data are transmitted in blocks, which requires dividing data coming to the serial port into blocks before transmitting data. A procedure for dividing data into blocks is as follows:

If data of pre-specified bytes [Conn. Byte] comes to the serial port of the ezTCP or if a specified period of time [TIMEOUT] elapses after first data reception, all data received for the same period is recognized as one block which is then transmitted to the UDP. The [TIMEOUT] unit is 10ms. If [TIMEOUT] is set to 2, the time period is between 20ms and 30ms.

Since UDP communication does not require a connection procedure, the user can establish N-to-M communication via multicast and broadcast.

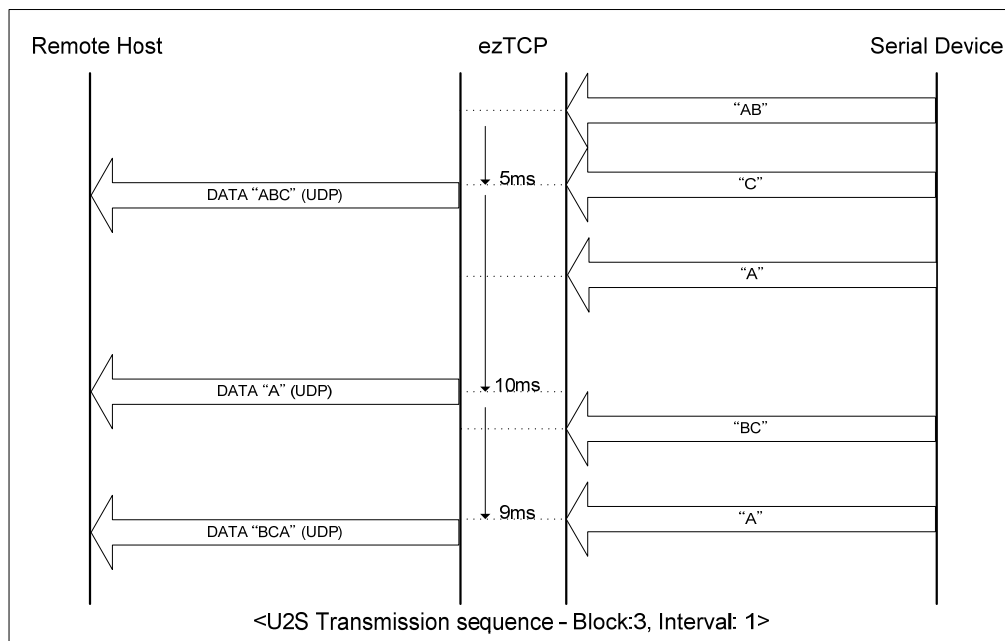

Set the following for U2S mode.

	Item	Description
IP address Related Item	Local IP Address	IP address of EZL-200L
	Subnet Mask	Subnet mask
	Gateway IP Address	IP address of gateway
	Local Port	Port number for UDP data receiving
	Peer IP Address	Peer IP address to transmit
	Peer Port	Peer port number to transmit
Serial Port	Baudrate	Serial port speed (bps)
	Data bits	Data bit length
	Parity	Parity
	Stop bit	Stop bit
	Flow Control	Flow control
Communication Mode	ezTCP Mode	Communication mode(U2S(3))
Packets	Block	UDP block size to transmit (unit: byte)
	Interval	Data gathering time from serial port to transmit as UDP (unit:10ms)
Configuration Method	ezConfig	Enable ezConfig function.
	Password	ezConfig password.

6. ATC Mode

6.1. Overview

EZL-200L can be controlled by AT commands in ATC mode. For example, the peer host IP address can be set by AT+PRIP command and connect to the host by ATD command.

Therefore, EZL-200L communicates several hosts alternatively.

And also, it provides passive connection function by ATA command.

6.1.1. AT command format

AT commands start with AT, and end <CR>.

AT command format is followed.

AT	Command	<CR>(0x0d)
----	---------	------------

The response code to AT command is followed.

Response message	<CR>(0x0d)	<LF>(0x0a)
------------------	------------	------------

Response Message

When ATV1 (initial setting)	When ATV0	Description
OK	0	command OK
CONNECT	1	TCP connected
NO CARRIER	3	TCP disconnected
ERROR	4	Command error
Set value	Set value	When query set value (example: AT+PRIP?)

6.2. Basic AT Command Set (Example: ATA, ATD etc.)

Command	Function	Description
A	passive connection	Listen connection (host → EZL-200L connection)
D	active connection	Connecting to host from EZL-200L
E	echo	Echo (E0 - no echo, E1-echo)
H	off-hook	disconnection
I	Inquiry	Output EZL-200 related-information
O	Online	To online mode
V	enable result code	Result code (numeric-V0, alphabetic-V1)

Z	reset	Reset
---	-------	-------

6.3. Extended AT Commands (Example: AT+PLIP etc.)

Command	Function	Description
+PLIP	local IP address	
+PSM	subnet mask	
+PGIP	default router	
+PLP	listening TCP port	
+PTO	timeout	
+PRIP	Remote machine IP address	
+PRP	Remote machine TCP port	
+PWP	Write configuration	Saving and Reset
+PRC	ezConfig enable/disable	ON: 1, OFF: 0
+PARP	ARP setting function enable/disable	ON: 1, OFF: 0
+PDC	DHCP enable/disable	ON: 1, OFF: 0

6.4. Online State and Online Command State

It is online command mode during disconnected. AT commands can be used in online command mode. After TCP connection, AT commands cannot be used. To use AT commands during the connection, change state to online command state.

Online Command State	During TCP disconnected, AT commands can be used To use AT commands during the connection, required escape sequence
Online State	During TCP connected, all serial data to EZL-200L convert TCP and send to ethernet

6.4.1. Changing Online State to Online Command State

To change online state to online command state during the connection, +++ string should be transmitted to EZL-200L as following time interval.

When transmitting +++ string to EZL-200L, +++ string will be sent to peer host.

The time from final data the first '+' data of	No data over 500ms(guard time)
--	--------------------------------

'+++ ' string	
time intervals between '+'s	0~500ms
Time interval after receiving last '+'	No data over 500ms (guard time)

6.4.2. Changing Online Command State to Online State

If EZL-200L's state is in online command state during TCP connection, EZL-200L's state can be changed into online state by an ATO command.

6.5. Example of Configuration with AT Command

	Serial Port		Description
	AT+PLIP=192.168.1.200<CR>	▶	Setting LOCAL IP address
◀	<CR><LF>OK<CR><LF>		Command OK
	AT+PGIP=192.168.1.254<CR>	▶	Setting GATEWAY IP address
◀	<CR><LF>OK<CR><LF>		Command OK
	AT+PSM=255.255.255.0<CR>	▶	Setting SUBNET MASK
◀	<CR><LF>OK<CR><LF>		Command OK
	AT+PLP=1470<CR>	▶	Setting LOCAL PORT
◀	<CR><LF>OK<CR><LF>		Command OK
	AT+PTO=10<CR>	▶	Setting TIME OUT
◀	<CR><LF>OK<CR><LF>		Command OK
	AT+PWP<CR>	▶	Saving setting value to EEPROM Reset automatically
◀	<CR><LF>OK<CR><LF>		Command OK
◀	<CR><LF>NO CARRIER<CR><LF>		System Reset

6.6. Example of TCP Connection

6.6.1. Example of Active Connection

	Serial Port		Description
	AT+PRIP=192.168.1.201<CR>	▶	Setting remote IP address to connect
◀	<CR><LF>OK<CR><LF>		Command OK
	AT+PRP=1470<CR>	▶	Setting remote port number to connect
◀	<CR><LF>OK<CR><LF>		Command OK
	ATDT<CR>	▶	Connecting to the host

Attempting to connect to the host		
◀	<CR><LF>CONNECT<CR><LF>	TCP connection success
Data Communication		

6.6.2. Example of passive Connection

	Serial Port		Description
	AT+PLP=1470<CR>	▶	Set LOCAL PORT to listen
◀	<CR><LF>OK<CR><LF>		Command OK
	ATA<CR>	▶	Passive connection command
Listen on local port from a host			
A host connects to EZL-200L			
◀	<CR><LF>CONNECT<CR><LF>		TCP connection OK
Data Communication			

6.7. Example of TCP Disconnection

6.7.1. Example of active disconnection

EZL-200L disconnects the connection.

	Serial Port		Description
Data Communication(during TCP connection)			
	[guard time]+++[guard time]	▶	Changing online state to online command state
◀	<CR><LF>OK<CR><LF>		Changed to online command state
	ATH	▶	TCP disconnection command
◀	<CR><LF>OK<CR><LF>		Command OK

6.7.2. Example of passive disconnection

The remote host disconnects the connection.

	Serial Port		Description
Data Communication(during TCP connection)			
The remote host disconnect the connection			
◀	<CR><LF>NO CARRIER<CR><LF>		TCP disconnected

7. Technical Support, Warranty, and Notes on Operation

7.1. Technical Support

If you have any question regarding operation of the product, visit Customer Support FAQ corner and the message board on Sollae Systems' web site or send us an email at the following address: support@eztcp.com

Website Address for Customer Support:

<http://www.sollae.co.kr/Support/index.html>

7.2. Warranty

7.2.1. Refund

Upon the customer's request to refund the product within two weeks after purchase, Sollae Systems will refund the product.

7.2.2. Free Repair Services

For product failures occurring within one year after purchase, Sollae Systems provides free repair services or exchange the product. However, if the product failure is due to user's fault, repair service fees will be charged or the product will be replaced at user's expense.

7.2.3. Charged Repair Services

For product failures occurring after the warranty period (one year) or resulting from user's fault, repair service fees will be charged and the product will be replaced at user's expense.

7.2.4. Notes on Operation

- Sollae Systems is not responsible for product failures occurring due to user's alternation of the product.
- Specifications of the product are subject to change without prior notice for performance improvement.

- Sollae Systems does not guarantee successful operation of the product if the product was used under conditions deviating from the product specifications.
- Reverse engineering of firmware and applications provided by Sollae Systems is prohibited.
- Use of firmware and applications provided by Sollae Systems for purposes other than those for which they were designed is prohibited.
- Do not use the product in an extremely cold or hot place or in a place where vibration is severe.
- Do not use the product in an environment in which humidity is high or a lot of oil exists.
- Do not use the product where there is caustic or combustible gas.
- Sollae Systems does not guarantee normal operation of the product under the conditions a lot of noise exists.
- Do not use the product for a purpose that requires exceptional quality and reliability relating to user's injuries or accidents - aerospace, aviation, health care, nuclear power, transportation, and safety purposes.
- Sollae Systems is not responsible for any accident or damage occurring while using the product.

8. Revision History

Date	Version	Comments
Aug.09.2005	1.3	Initial Release
Dec.26.2005	1.4	Added Revision History Added Trash Mark for WEE